

CE IE3

MADE IN ITALY



**INDUSTRIAL range**



## K-MAX

Gearless direct drive  
oil-injected  
screw compressors



Fixed and Variable Speed  
5.5-15 kW

# Company profile

FINI boasts more than 60 years of experience and is one of the most important global organisations in the professional and industrial compressed air sector. Synonymous with quality and professionalism, the Fini brand not only provides one of the most comprehensive ranges in the field of rotary air compressors, but above all Fini is now established as a global reference point in terms of quality and technology recognised throughout the industrial compressed air sector.



All Fini industrial compressors are **MADE IN ITALY** and are designed for heavy duty use and distinguished by offering unique and advanced technologies that provides energy saving solutions that work!

► Our compressors offer the ideal solution to the needs of larger-scale industry as well as smaller and mid-sized companies, where compressed air is a most important source of energy.

Fini Screw Compressors are designed for continuous duty in the most arduous operating conditions, with a special attention to reducing energy consumption, lowering operating and maintenance costs along with offering simple installation and ease of use.

► The entire production process, from project design and research through to packaging of the final product is carried out at our facilities in Italy.

Our highly skilled work force are dedicated to supporting the manufacturing and assembling activities.

The continuous control and monitoring of each manufacturing process grants the utmost precision at every step, in order to achieve the highest quality, supreme product reliability and flexibility of use.

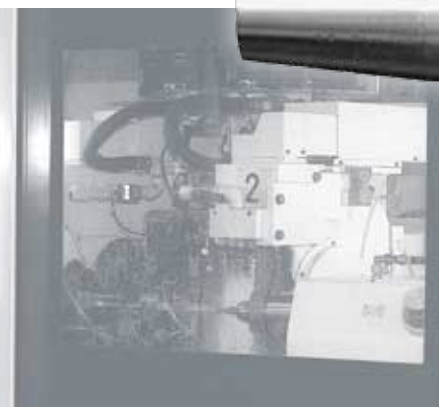
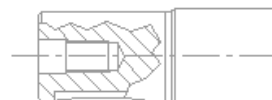

# Innovation, Quality and Know-how

Our engineering philosophy is based on the selection and highly controlled assembly of the most reliable and efficient technical solutions. The constant pursuit of excellence in quality along with an innovative spirit and particular attention to the customers demands, are the values that have always characterised FINI and its products.

► The continuous investment in technical design and product innovation has allowed FINI to take a further step forward in the sector, with the launch of the latest **range of industrial air compressors K-MAX Series: oil-injected gearless direct-driven rotary screw compressors**, in an extensive range from 5.5 to 15 kW.



► During production all of the assembly and testing of products is performed on automated assembly lines that utilise the latest robotic systems. The use of the most advanced and modern machine tools in manufacturing coupled with the employment of advanced controls and processes have been a major focus for the Company representing a very significant investment in order to create products that exceed the quality standards demanded by the market.

Since 1996, the Company has certified its quality systems in compliance with UNI EN ISO 9001.

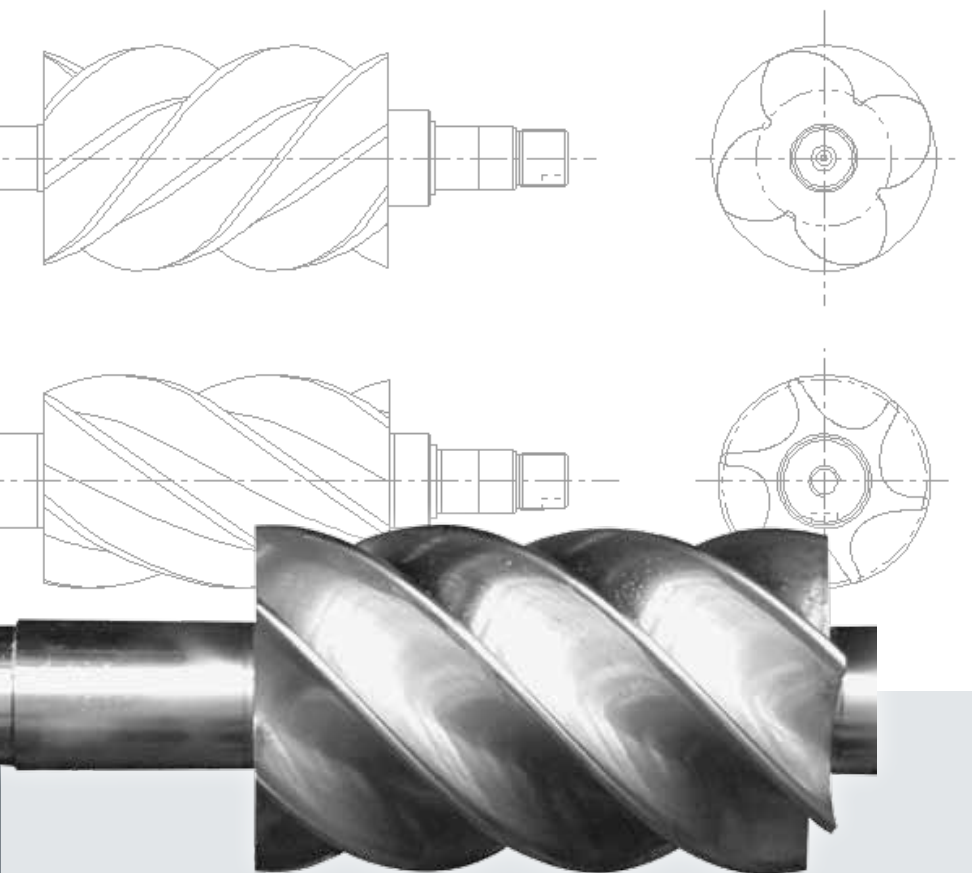



# Our TARGET: Maximum efficiency, lower energy consumption and total convenience.

The new gearless direct-driven oil injected K-MAX screw compressors have been designed to minimise energy costs, without sacrificing performance. The modularity and flexibility of these products provide multiple solutions suitable for different user's requirements: with or without air receiver, with or without refrigerated dryer, in fixed speed or variable speed formats.

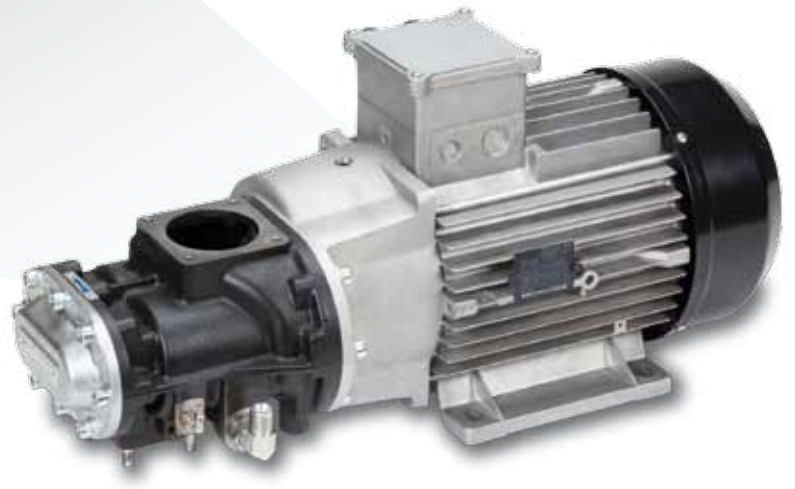
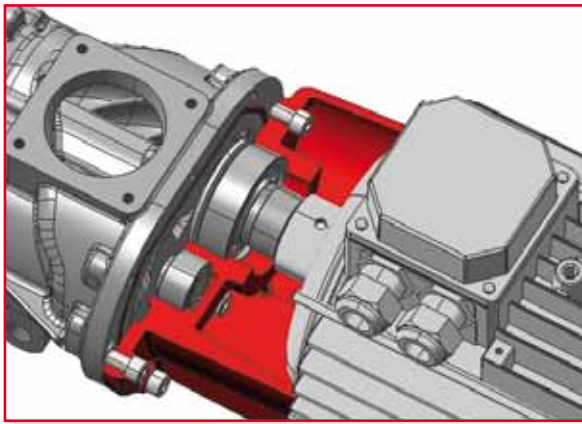

## ▲ Gearless direct drive transmission

The drive between the air-end and electric motor is carried out by means of gearless direct connection. Power transmission without loss can reach an advantage up to 4% in front of a normal belt driven compressor, thanks to the special motor with tubular crankcase and no frontal bearing: this connection doesn't need flexible coupling for compressor maximum reliability and efficiency and no drive maintenance.



# Why you should choose a Fini SCREW compressor?

- ▶ To control and reduce operating costs.
- ▶ To provide the most modern, compact, efficient, reliable and quiet rotary screw compressor.
- ▶ To provide a continuous source compressed air.
- ▶ To increase operational efficiency in all areas where compressed air is used.
- ▶ To save energy and reduce CO<sub>2</sub> emissions.



## High energy saving

The choice of high quality components, combined with our high performance air-ends and **Premium Efficiency IE3 motors**, ensure reduced power consumption, substantial energy savings and exceptional performance. Furthermore, the IE3 motors reduce CO<sub>2</sub> emissions: an important contribution to protecting the environment.

## Plug&Play

K-MAX compressors are thoroughly tested at our factories to ensure they are ready for immediate use following delivery, thereby saving time and cutting installation costs.

## Low noise level

K-MAX compressors are very quiet: the use of very efficient soundproofing materials make them suitable for installation even near workstations.

## High reliability

The use of premium components from primary global manufacturers along with our advanced assembly with strict quality control and testing, results in a final product that offers a long service life with maximum reliability and fewer maintenance interventions.

## High efficiency

Higher air output performance is a key focus for the renowned FINI project engineering and design team. The K-MAX series follows this tradition by offering premium performance levels across the entire range.

## Very compact design

The very compact design enables K-MAX compressors to be installed close to the application reducing installation costs and improving efficiency.

Our air-ends, inverters and controllers are covered by **2 YEARS WARRANTY**

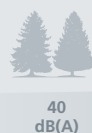
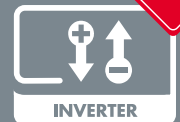

# K-MAX 5.5-7.5 kW: compact design meets high performance.



## K-Max 5.5

5.5 kW

### Available versions:

- floor mounted compressor
- compressor + air receiver
- compressor + air receiver + air dryer

### Air-end:

FSC 26



### Controller:

ETIV



Fixed speed

## K-Max 7.5

7.5 kW

### Available versions:

- floor mounted compressor
- compressor + air dryer
- compressor + air receiver
- compressor + air receiver + air dryer

### Air-end:

FSC 26



### Controller:

ETIV



Fixed and variable speed

# K-MAX 11-15 kW: a quality choice.

The Fini K-MAX series is available in a variety of configurations to suit the exact requirements of the customer: starting with the standard floor mounted version, the range can also be selected with a 270 or 500 litre air receiver, with or without refrigerated dryer, also available with inverter (variable speed control) drive. The whole machine forms an extremely compact and aesthetic design.

- ▶ **Direct drive technology for maximum reliability.**
- ▶ **High performances provides excellent efficiency.**
- ▶ **Intelligent microprocessor control system.**
- ▶ **Very compact design.**
- ▶ **No drive belts for less maintenance.**



### Dryer module

K-MAX compressors are also available with dryer ("ES" versions): supplied ready to operate with a minimum of installation.

## K-Max 11

### 11 kW

#### Available versions:

- floor mounted compressor
- compressor + air dryer
- compressor + air receiver
- compressor + air receiver + air dryer

#### Air-end:

FSC 50



#### Controller:

ETIV



Fixed and variable speed

## K-Max 15

### 15 kW

#### Available versions:

- floor mounted compressor
- compressor + air dryer
- compressor + air receiver
- compressor + air receiver + air dryer

#### Air-end:

FSC 50



#### Controller:

ETIV



Fixed and variable speed



# ETIV Advanced electronic controller

The advanced ETIV controller installed on the K-MAX range has been specially designed to ensure optimal monitoring and regulation of the operation of the compressor, allowing flexibility and complete programming, to ensure maximum efficiency and safety.



Controller with multi-function backlight LCD graphic display, the menu is drop down type.

In the main screen display indicates:

- ▶ Working pressure (offload/load);
- ▶ Oil temperature;
- ▶ Compressor status (stand-by, offload, load);
- ▶ Fan status (off/on);
- ▶ Date and time;
- ▶ Hours remaining before maintenance;
- ▶ Inverter use percentage.

## ▶ Compressor rotation management for up to 4 units.

It is possible to connect up to 4 compressors for managing distribution of the workload in such a way to equalize the hours but also changing set pressures of the various compressors for different times.

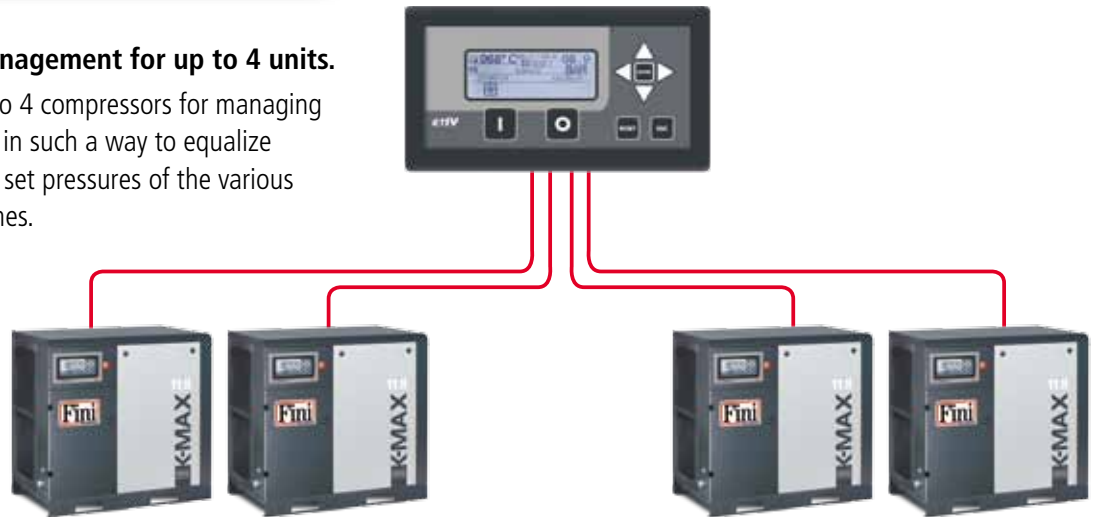

# SMS Device Service Management System

SMS is the innovative device to allow the remote control of the compressor and to perform predictive maintenance available on screw compressors equipped with the latest ETIV controller. The device automatically sends an e-mail (up to 3 addresses to be defined during set-up) in case of an alarm and according to preset thresholds (every hour, every day, every week): this feature allows you to accurately schedule routine maintenance and to allow intervention in case of special maintenance or fault finding. Furthermore, you can have remote control from any device (tablet, smartphone, PC, notebook, etc.), via a web page, as long as it is connected to the same Internet network as the SMS device.

Predictive and targeted maintenance:

- ▶ automated e-mail in case of alarms,
- ▶ automated e-mail every hour / day / week.

Compressor remote control:

- ▶ access to the various menu levels (user, service),
- ▶ check the status of the compressor online,
- ▶ on/off control,
- ▶ no software to be installed.





# Variable speed drive

Nowadays, the reduction of the energy consumption has become a global challenge in terms of environmental impact. Reducing power consumption and protecting our valuable energy resources represents one of the greatest global environmental challenges of our times.

The **K-Max series** version with **7.5, 11 and 15 kW** electric motor are available in a variable speed drive version, providing high performance combined with the most effective energy saving solution.

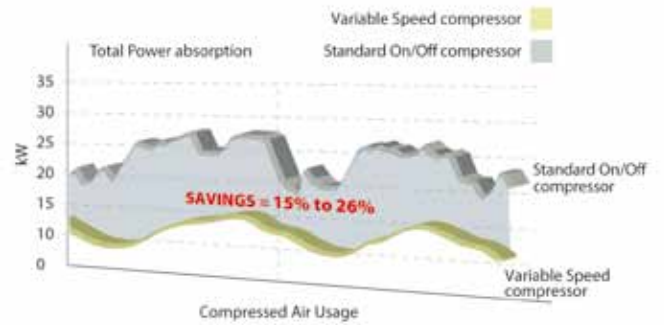

The graph below shows the significant energy saving using variable speed compressors in a typical installation.

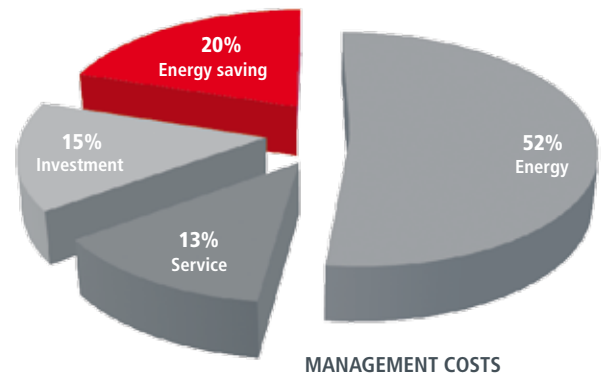

The application of a frequency inverter, able to dynamically adjust the voltage/frequency/current values of the motor, allows the elimination of unnecessary power losses by constantly adjusting the generation of compressed air to match the real air demand, offering many proven advantages for the user in terms of reducing energy consumption:

- ▶ Continuous regulation of the motor speed and compressed air generation to precisely match the air demand.
- ▶ The air output is constantly adjusted between 40% and 100% of the compressor full capacity.
- ▶ Constant and accurate air pressure control.
- ▶ Energy consumption is proportional to the delivered compressed air, so you only pay for the compressed air that is used!

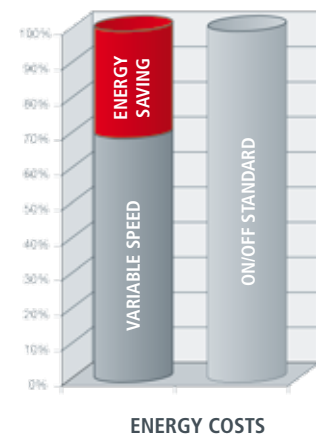

Designed for a long service life



# Noise and temperature under control



## ■ Innovative cooling system

The cooling system is among the most innovative in the field.

A thermostatic controlled centrifugal fan keeps the temperature of the entire compressor to specific tolerance and at a constant level, avoiding temperature peaks that can be harmful for the correct operation of the compressor. The action of the fan, combined with the efficiency of the oversized oil cooler, guarantees the ideal operation of the compressor in differing and even extreme climatic conditions. The "silent" fans along with the specially designed labyrinth ventilation and the use of top quality soundproofing materials ensure one of the lowest acoustic levels of any air compressor.



## ■ Cleaner components in any conditions

The pre-filtering panel separates incoming dust and keeps the inside of the machine clean, thereby increasing the longevity of internal components and reducing operating temperature.



## ■ High performance ROTARY SCREW AIR-ENDS

The Fini air ends are entirely designed, produced and tested at our Italian facilities: the special design of the screw profile ensures high performance, low temperature and reduced energy consumption.



## ■ SPIN-ON filters

The oil filter and oil-separator filter are easy to remove and replace whilst offering a long service life with low maintenance costs.



## ■ Intake valve

The intake valve is entirely designed and manufactured at our facilities. This most important device, adjusts the compressor's operation to guarantee minimum pressure during idle running and maximum savings upon start-up.



## ■ Easy handling

All tanks are equipped with anti-tip brackets for safe handling with transpallet. The air storage tanks have drain cock in a easily accessible position and are equipped with ball valve.



## ■ Accurate working pressure

The use of a digital transducer guarantees an accurate and stable function during operation. It allows direct modification of the working pressure from the electronic controller without any mechanical intervention.

# HRS Heat Recovery System

**HRS is a system for the recovery of the heat generated by the screw compressors, for the production of hot water.**

Most of the energy used to produce compressed air is actually converted into heat: up to 90% of this energy is reusable! About 75% of the energy used is found in the lubrication and cooling circuit and can be used as a heat source, the remaining 15% is contained in the compressed air. It is therefore easier to produce the compressed air which enters the network. It is therefore quite simple to recover the thermal energy (for alternative use) in the compression process... valuable energy that is normally wasted!



▶ Plate oil-water heat exchanger

▶ Water pump

The HRS system can be used on all oil-injected screw compressors.

## HEAT OF COMPRESSION

- 4% Heat remaining in the air
- 2% Losses by radiation
- 13% Heat removed from the air cooler
- 72% Heat removed from the oil cooler
- 9% Heat radiated by the electric motor

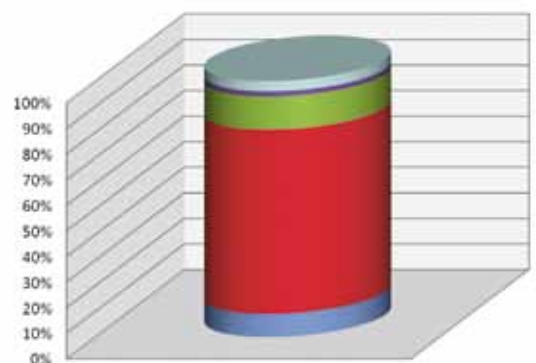



# Recover energy - Save money!



How great the recovery of energy actually is, depends of course on the size of the compressors and the type of replaced energy (electricity, gas, heating oil), but the investment becomes very interesting for the compressors starting from 11 kW installed power. Given the current energy costs, the return on investment of a typical heat recovery system can be as short as 6 months with less than 2 years being the standard (with reference to a plate heat exchanger for heating systems).

Heat recovery is a real opportunity to increase the effectiveness of a compressed air system, the impact on energy costs allows greater savings, up to 3 times compared to even the most efficient compressor.



# Optimised control in the compressor room

Many compressed air stations include several compressors: EasyX4 is a weekly programmable sequencer, capable of configuring up to 4 compressors, based on the amount of air actually required.

**EasyX4 is the easiest solution for compressor sequencing and supervision over complex systems of compressors, up to 4 units: fixed or variable speed.**

The programming is intuitive. It is sufficient to set the 4 pressure ranges (if 4 is the number of connected units) and later define at what time the entire compressor station shall start and stop, assigning at which pressure each compressor must work.



EasyX4 sequencer  
code #405531604



- Three programming levels:**
- ▶ **MANUAL:** compressors are fixed to a given operational pressure range;
  - ▶ **AUTOMATIC:** with pressure range swapping after a programmable time interval;
  - ▶ **GROUP PROGRAMMING:** where compressors can be switched within groups.

# High quality compressed air, safeguarding the final product quality

The compression process increases the concentration of solid particles suspended in the atmosphere, generated by natural phenomena but also by polluting agents or industrial processes.

Water, oil, impurities and odours cause many issues in respect of the quality of the air produced, corrosion to pipe work and damage to the pneumatic equipment, thus negatively affects performance, efficiency and reliability.

The quality of compressed air is therefore fundamental for the reliability of the machinery and quality of the final product.

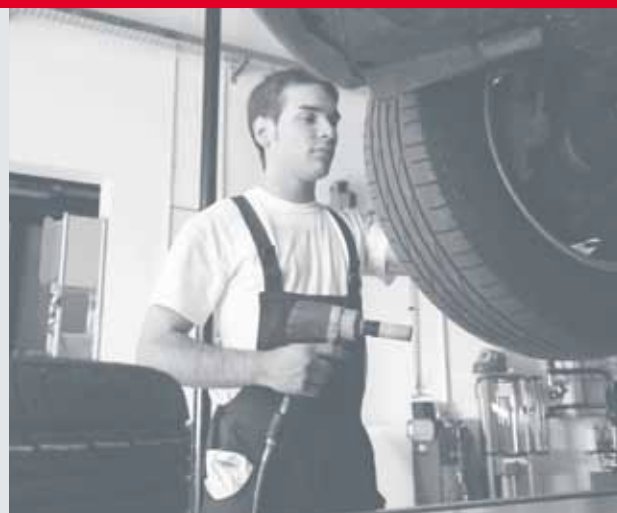

Fini has developed **refrigerated dryers that are integrated with the compressor**, with centralised condensate drain, in order to:

- ▶ Obtain clean air that is free from condensate and impurities;
- ▶ Reduce maintenance costs and down time;
- ▶ Protecting all down stream equipment and their investment costs;
- ▶ Safeguarding the environment and the quality of the final product;
- ▶ Compliance with safety standards.

## Efficient, functional, ecologic.

The refrigerated air dryer ensures the production of high quality dry compressed air that is essential to maintaining reliable systems and to ensure the highest quality of the finished product.

The refrigerated dryer achieves excellent performance even in unfavourable environmental conditions, and high inlet temperatures.

## HEAT EXCHANGER

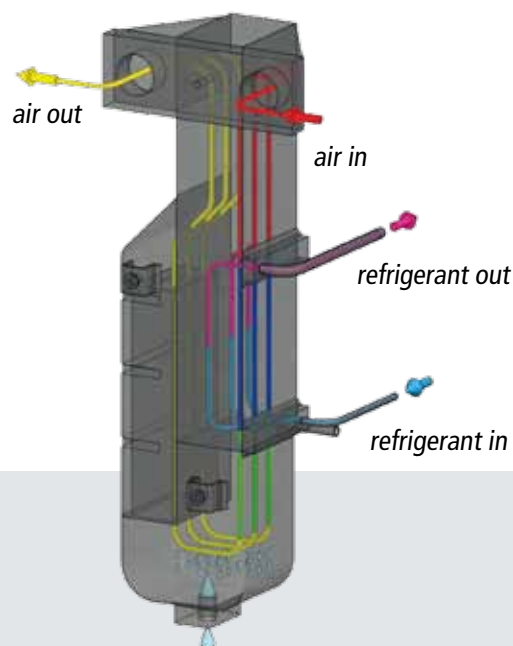

The highly efficient and ultra compact heat exchanger is able to operate effectively in ambient temperatures up to 45°C, ensuring a reduced compressed air pressure drop.

This compact aluminium module contains the various stages of the compressed air treatment.

**Air-air exchanger:** a pre-cooling of the intake air takes place in this section.

This allows to reduce the energy consumption of the refrigeration circuit and reduces the possibility of condensation on the outer surface of the pipe from the dryer.

**Air-gas exchanger:** the pre-cooled air in the air/air heat exchanger comes in the evaporator and cools to the dew point.

**Demister:** the air cooled in the evaporator passes through a demister separator that allows the drainage of the condensate in a large collection chamber. The geometry of the module and the demister allows to keep the load losses low.



Code	ℓ	Product	Compressor		Air delivered			MAX		dB(A)	BSP	Weight		L x D x H (cm)
			kW	HP	l/min.	m³/h	c.f.m.	bar	psi			kg	Lbs	
<b>FLOOR MOUNTED</b>														
V51PS92FNM760	-	K-MAX 5.5-10	5.5	7.5	705	42	25	10	145	62	1/2"	160	353	80 x 65 x 85
V51PT92FNM760	-	K-MAX 7.5-10	7.5	10	1050	63	37	10	145	62	1/2"	165	364	80 x 65 x 85
V51PY92FNM760	-	K-MAX 7.5-13	7.5	10	700	42	25	13	188	62	1/2"	165	364	80 x 65 x 85
V60PU92FNM760	-	K-MAX 11-08	11	15	1700	102	60	8	116	68	3/4"	240	529	100 x 70 x 100
V60PJ92FNM760	-	K-MAX 11-10	11	15	1550	93	55	10	145	68	3/4"	240	529	100 x 70 x 100
V60PW92FNM760	-	K-MAX 11-13	11	15	1200	72	42	13	188	68	3/4"	240	529	100 x 70 x 100
V60PV92FNM760	-	K-MAX 15-10	15	20	2100	126	74	10	145	68	3/4"	250	551	100 x 70 x 100
V60PX92FNM760	-	K-MAX 15-13	15	20	1550	93	55	13	188	68	3/4"	250	551	100 x 70 x 100
<b>WITH DRYER</b>														
V51PT92FNM860	-	K-MAX 7.5-10 ES	7.5	10	1050	63	37	10	145	62	1/2"	200	441	109 x 65 x 85
V60PU92FNM860	-	K-MAX 11-08 ES	11	15	1700	102	60	8	116	68	3/4"	282	622	136 x 70 x 100
V60PJ92FNM860	-	K-MAX 11-10 ES	11	15	1550	93	55	10	145	68	3/4"	282	622	136 x 70 x 100
V60PW92FNM860	-	K-MAX 11-13 ES	11	15	1200	72	42	13	188	68	3/4"	282	622	136 x 70 x 100
V60PV92FNM860	-	K-MAX 15-10 ES	15	20	2100	126	74	10	145	68	3/4"	292	644	136 x 70 x 100
V60PX92FNM860	-	K-MAX 15-13 ES	15	20	1550	93	55	13	188	68	3/4"	292	644	136 x 70 x 100
<b>WITH TANK</b>														
V91PS92FNM701	270	K-MAX 5.5-10-270	5.5	7.5	705	42	25	10	145	62	1/2"	260	573	120 x 65 x 154
V91PT92FNM701	270	K-MAX 7.5-10-270	7.5	10	1050	63	37	10	145	62	1/2"	265	584	120 x 65 x 154
V83PT92FNM701	500	K-MAX 7.5-10-500	7.5	10	1050	63	37	10	145	62	1/2"	330	727	200 x 65 x 154
V83PU92FNM701	500	K-MAX 11-08-500	11	15	1700	102	60	8	116	68	3/4"	422	930	200 x 73 x 170
V83PJ92FNM701	500	K-MAX 11-10-500	11	15	1550	93	55	10	145	68	3/4"	422	930	200 x 73 x 170
V83PW92FNM701	500	K-MAX 11-13-500	11	15	1200	72	42	13	188	68	3/4"	422	930	200 x 73 x 170
V83PV92FNM701	500	K-MAX 15-10-500	15	20	2100	126	74	10	145	68	3/4"	442	974	200 x 73 x 170
V83PX92FNM701	500	K-MAX 15-13-500	15	20	1550	93	55	13	188	68	3/4"	442	974	200 x 73 x 170
<b>WITH TANK AND DRYER</b>														
V91PS92FNM801	270	K-MAX 5.5-10-270 ES	5.5	7.5	705	42	25	10	145	62	1/2"	295	650	120 x 65 x 154
V91PT92FNM801	270	K-MAX 7.5-10-270 ES	7.5	10	1050	63	37	10	145	62	1/2"	300	661	120 x 65 x 154
V83PT92FNM801	500	K-MAX 7.5-10-500 ES	7.5	10	1050	63	37	10	145	62	1/2"	380	838	200 x 65 x 154
V83PU92FNM801	500	K-MAX 11-08-500 ES	11	15	1700	102	60	8	116	68	3/4"	464	1023	200 x 73 x 170
V83PJ92FNM801	500	K-MAX 11-10-500 ES	11	15	1550	93	55	10	145	68	3/4"	464	1023	200 x 73 x 170
V83PW92FNM801	500	K-MAX 11-13-500 ES	11	15	1200	72	42	13	188	68	3/4"	464	1023	200 x 73 x 170
V83PV92FNM801	500	K-MAX 15-10-500 ES	15	20	2100	126	74	10	145	68	3/4"	484	1067	200 x 73 x 170
V83PX92FNM801	500	K-MAX 15-13-500 ES	15	20	1550	93	55	13	188	68	3/4"	484	1067	200 x 73 x 170

Free air delivery as per ISO 1217 Annex C, at 7.5 - 9.5 - 12.5 bar at the compressor outlet. ± 3 dB (A) as PNEUROP/CAGI PN-NTC 2.3.





Codice	l	Prodotto	Compressor		Air delivered (max. / min.)			MAX		dB(A)	BSP	Weight		L x D x H (cm)
			kW	HP	l/min.	m³/h	cf.m.	bar	psi			kg	Lbs	
<b>VARIABLE SPEED</b>														
V51QT97FNM760	-	K-MAX 7.5-08 VS	7.5	10	1300 / 520	78 / 31	46 / 18	8	116	63	1/2"	180	397	80 x 65 x 85
V51PT97FNM760	-	K-MAX 7.5-10 VS	7.5	10	1100 / 440	66 / 26	39 / 16	10	145	63	1/2"	180	397	80 x 65 x 85
V60PU97FNM760	-	K-MAX 11-08 VS	11	15	1700 / 680	102 / 41	60 / 24	8	116	68	3/4"	256	564	100 x 70 x 100
V60PJ97FNM760	-	K-MAX 11-10 VS	11	15	1580 / 620	95 / 37	56 / 22	10	145	68	3/4"	256	564	100 x 70 x 100
V60PI97FNM760	-	K-MAX 15-08 VS	15	20	2500 / 950	150 / 57	88 / 34	8	116	68	3/4"	276	608	100 x 70 x 100
V60PV97FNM760	-	K-MAX 15-10 VS	15	20	2100 / 840	126 / 50	74 / 30	10	145	68	3/4"	276	608	100 x 70 x 100
<b>VARIABLE SPEED WITH DRYER</b>														
V51QT97FNM860	-	K-MAX 7.5-08 ES VS	7.5	10	1300 / 520	78 / 31	46 / 18	8	116	63	1/2"	215	474	109 x 65 x 85
V51PT97FNM860	-	K-MAX 7.5-10 ES VS	7.5	10	1100 / 440	66 / 26	39 / 16	10	145	63	1/2"	215	474	109 x 65 x 85
V60PU97FNM860	-	K-MAX 11-08 ES VS	11	15	1700 / 680	102 / 41	60 / 24	8	116	68	3/4"	298	657	136 x 70 x 100
V60PJ97FNM860	-	K-MAX 11-10 ES VS	11	15	1580 / 620	95 / 37	56 / 22	10	145	68	3/4"	298	657	136 x 70 x 100
V60PI97FNM860	-	K-MAX 15-08 ES VS	15	20	2500 / 950	150 / 57	88 / 34	8	116	68	3/4"	308	679	136 x 70 x 100
V60PV97FNM860	-	K-MAX 15-10 ES VS	15	20	2100 / 840	126 / 50	74 / 30	10	145	68	3/4"	308	679	136 x 70 x 100
<b>VARIABLE SPEED WITH TANK</b>														
V91QT97FNM701	270	K-MAX 7.5-08-270 VS	7.5	10	1300 / 520	78 / 31	46 / 18	8	116	63	1/2"	280	617	120 x 65 x 154
V91PT97FNM701	270	K-MAX 7.5-10-270 VS	7.5	10	1100 / 440	66 / 26	39 / 16	10	145	63	1/2"	280	617	120 x 65 x 154
V83PU97FNM701	500	K-MAX 11-08-500 VS	11	15	1700 / 680	102 / 41	60 / 24	8	116	68	3/4"	438	966	200 x 73 x 170
V83PJ97FNM701	500	K-MAX 11-10-500 VS	11	15	1580 / 620	95 / 37	56 / 22	10	145	68	3/4"	438	966	200 x 73 x 170
V83PI97FNM701	500	K-MAX 15-08-500 VS	15	20	2500 / 950	150 / 57	88 / 34	8	116	68	3/4"	458	1010	200 x 73 x 170
V83PV97FNM701	500	K-MAX 15-10-500 VS	15	20	2100 / 840	126 / 50	74 / 30	10	145	68	3/4"	458	1010	200 x 73 x 170
<b>VARIABLE SPEED WITH TANK AND DRYER</b>														
V91QT97FNM801	270	K-MAX 7.5-08-270 ES VS	7.5	10	1300 / 520	78 / 31	46 / 18	8	116	63	1/2"	315	694	120 x 65 x 154
V91PT97FNM801	270	K-MAX 7.5-10-270 ES VS	7.5	10	1100 / 440	66 / 26	39 / 16	10	145	63	1/2"	315	694	120 x 65 x 154
V83PU97FNM801	500	K-MAX 11-08-500 ES VS	11	15	1700 / 680	102 / 41	60 / 24	8	116	68	3/4"	480	1058	200 x 73 x 170
V83PJ97FNM801	500	K-MAX 11-10-500 ES VS	11	15	1580 / 620	95 / 37	56 / 22	10	145	68	3/4"	480	1058	200 x 73 x 170
V83PI97FNM801	500	K-MAX 15-08-500 ES VS	15	20	2500 / 950	150 / 57	88 / 34	8	116	68	3/4"	500	1102	200 x 73 x 170
V83PV97FNM801	500	K-MAX 15-10-500 ES VS	15	20	2100 / 840	126 / 50	74 / 30	10	145	68	3/4"	500	1102	200 x 73 x 170

Free air delivery as per ISO 1217 Annex C, at 7.5 - 9.5 bar at the compressor outlet. ± 3 dB (A) as PNEUROP/CAGI PN-NTC 2.3.

# Long Life Kit for screw compressors scheduled maintenance

- ▶ **FSN original spare parts** have been rigorously selected, checked and tested by specialised technicians to ensure the utmost efficiency and endurance of the compressor. The parts are stocked in our "LOGIMAT" centralised and automated warehouse in Zola Predosa (BO) - Italy, where 12,000 part codes on 10,000 sqm are managed every day.
- ▶ Specialised staff are continuously in contact with our distribution centres worldwide, to deliver spare parts to our customers in the shortest possible time.
- ▶ The use of **FSN Long Life Kit**, specifically studied for screw compressors, extends maintenance intervals, cutting down service costs and ensuring consistent product performance.  
**Ask for the catalog with reference codes, suitable for all K-MAX compressors.**



Maintenance interval, using original parts **+20%**



<b>K-MAX 5.5 - 15 kW</b>		
<b>1,000 h</b> (or every year)	<b>4,000 h</b> (or every year)	<b>12,000 h</b>
1 Air filter cartridge	<b>KIT B</b> 1 Air filter cartridge 1 Oil filter cartridge 1 Separator cartridge 1 Oil check valve 1 Prefilter	<b>KIT E</b> 1 Kit 4,000 h 1 Solenoid valve 1 Minimum pressure valve kit
<b>K-MAX VS 7.5 - 15 kW</b>		
<b>1,000 h</b> (or every year)	<b>4,000 h</b> (or every year)	<b>12,000 h</b>
1 Air filter cartridge	<b>KIT B</b> 1 Kit 4,000 h 1 Electric cabinet prefilter	<b>KIT E</b> 1 Kit 4,000 h VS 1 Solenoid valve

We recommend to change oil at the indicated intervals (see user's manuals) or every year. We suggest to use our RotEnergyPlus oil (NOT INCLUDED IN THE LONG LIFE KIT).

# RotEnergy synthetic base lubricants

- ▶ FSN lubricants are specially designed for rotary screw compressors to achieve rapid water separation, lower friction, enhanced energy savings, longer maintenance intervals and excellent bearing lubrication while offering superior rust and corrosion protection.
- ▶ RotEnergyFood is a high quality food-grade rotary compressor lubricant specifically designed for use in the food and beverage industries to meet their production quality standards.



#600000018	RotEnergyPlus 46 cSt - 1 x 3.25 kg (3.75 lt) package
#600000009	RotEnergyPlus 46 cSt - 4 x 3.25 kg (3.75 lt) packages
#600000007	RotEnergyPlus 46 cSt - 1 x 16 kg (18.5 lt) package
#600000012	RotEnergyPlus 46 cSt - 1 x 175 kg (210 lt) can
#600000014	RotEnergyFood 46 cSt - 4 x 3.25 kg (3.75 lt) packages
#600000016	RotEnergyFood 46 cSt - 1 x 16 kg (18.5 lt) package
#600000017	RotEnergyFood 46 cSt - 1 x 180 kg (207 lt) can



## FSN original spare parts



- ▶ Our "Hot-Line" service is able to prepare and ship urgent orders on the same day.
- ▶ All the exploded drawings and the spare parts lists for every compressor model are available at any time on the Fini and FSN websites:  
[www.finicompressors.com](http://www.finicompressors.com) - [www.fsnspareparts.com](http://www.fsnspareparts.com)

## A wide range of solutions for industrial applications



### **K-Max 22-38**

Gearless direct drive oil-injected screw compressors, from 22 to 37 kW power, fixed and variable speed.



### **Micro - Plus**

Belt-driven oil-injected rotary screw compressors, from 2.2 to 75 kW power, fixed and variable speed.



### **Tera SD**

Gearless direct drive oil-injected screw compressors, from 75 to 250 kW power, fixed and variable speed.



### **OS Scroll**

Oil-free spiral scroll compressors, from 2.2 to 22 kW power, single or multi-scroll, fixed and variable speed.



### **Air Treatment**

Air dryers, air filters and a wide range of products for the compressed air treatment.



### **FINI NUAIR S.p.A.**

Registered office and Headquarter: Via Einaudi, 6 - 10070 Robassomero (TO) - Italy

Production plant: Via Toscana, 21 - 40069 Zola Predosa (BO) - Italy

Tel.: +39 011 9233000 - Fax: +39 011 9241138

[www.finicompressors.com](http://www.finicompressors.com) - [info@finicompressors.it](mailto:info@finicompressors.it)

